

ELEVATION VIEW TYPE-3

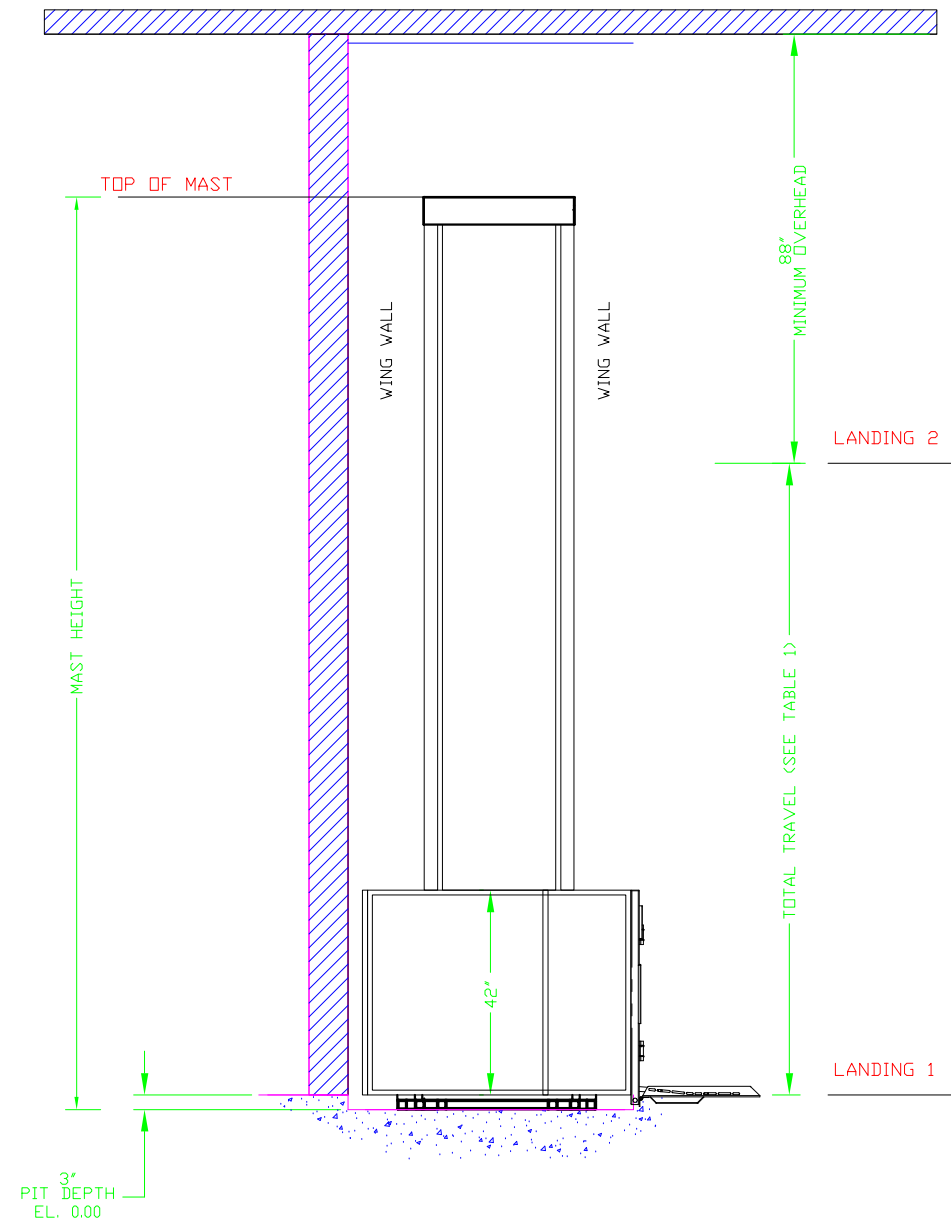
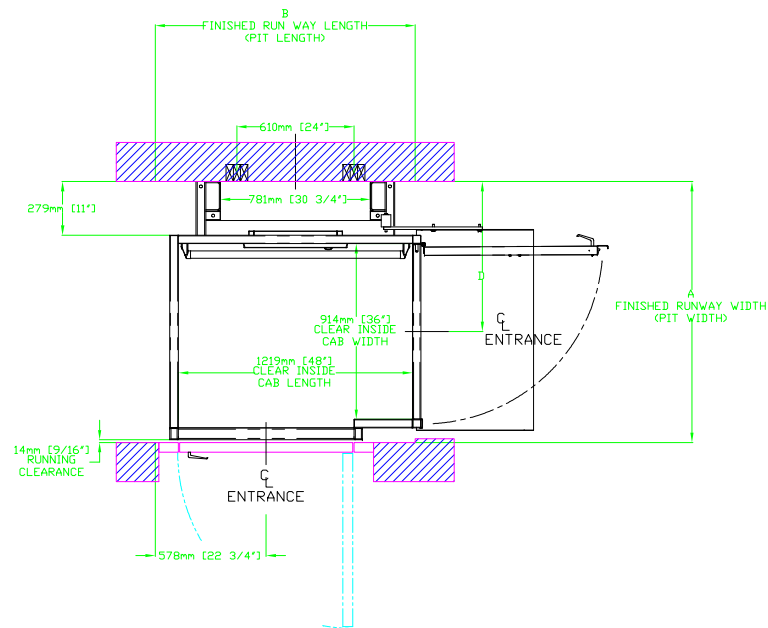

TABLE 1- MAST HEIGHT*

Max.Travel mm (Inches)	Extension Height mm (Inches)					Mast Height with 4.188" CAP	
	2388 (94")	1778 (70")	1168 (46")	559 (22")	254 (10")	mm	Inches
1219 (48")	1				1	2748	108.188
1524 (60")	1			1		3053	120.188
1829 (72")	1			1	1	3662	144.188
2438 (96")	1		1			4221	166.188
2743 (108")	1	1				4475	176.188
3048 (120")	1	1			1	4882	192.188
3657 (144")	2				1	5440	214.188
4267 (168")	2		1			6050	238.188
4877 (192")	2	1				6609	260.188
5486 (216")	3					7269	286.188
6096 (240")	3			1		7828	308.188
2706 (264")	3			1		8438	332.188
7010 (276")	3			1	1	8692	342.188

*EXAMPLE TABLE WITH 3" PIT, DIMENSIONS VARY WITH TRAVEL

V1504 TOP VIEW TYPE-3 ; 36" OPEN B WALL



FORCES

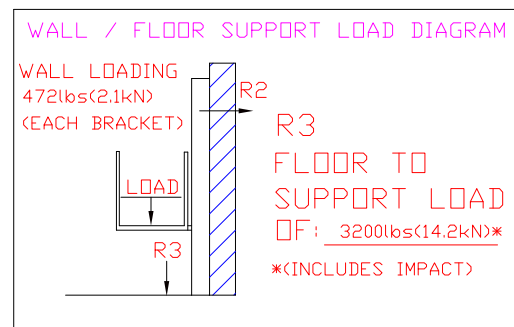

ANCHOR POINTS

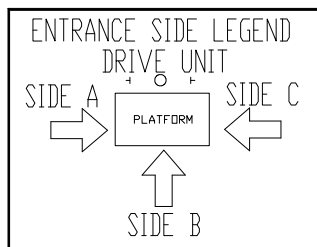
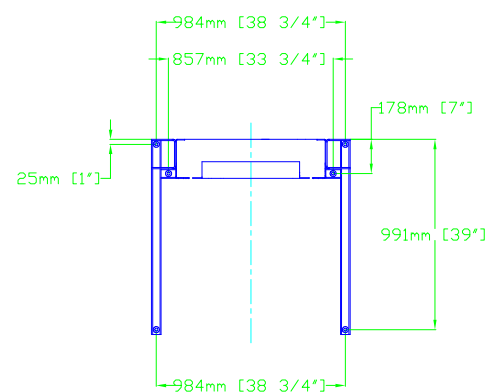
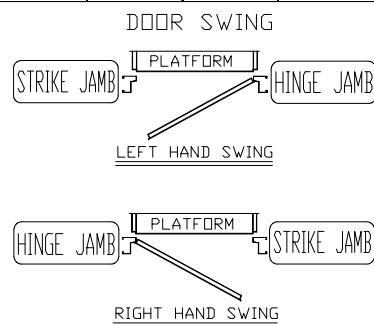

TABLE 2- HOISTWAY DIMENSION

CLEAR INSIDE CAB WIDTH		CLEAR INSIDE CAB LENGTH		A FINISHED RUNWAY WIDTH		B FINISHED RUNWAY LENGTH		C TOWER CENTER LINE		D DOOR CENTER LINE (IN CASE OF 36" DOOR)	
mm	Inches	mm	Inches	mm	Inches	mm	Inches	mm	Inches	mm	Inches
914	36	1219	48	1359	53 1/2	N/A	N/A	N/A	N/A	781	30 3/4
914	36	1372	54	1359	53 1/2	N/A	N/A	N/A	N/A	781	30 3/4
914	36	1524	60	1359	53 1/2	N/A	N/A	N/A	N/A	781	30 3/4



THE INFORMATION DISCLOSED HEREIN IS THE EXCLUSIVE PROPERTY OF

AND MAY NOT BE USED BY OTHERS WITHOUT PRIOR WRITTEN CONSENT

TITLE: V1504 TYPE - 3

CUSTOMER:	DATE:	11/12/2009	REVISION:	000
	SCALE:	1:1	DATE:	08/24/2009
PROJECT:	DRAFTER:	PHILLIP TRAN	SHEET 1 OF 1	
	LOCATION:	DRAWING NO:	V1504 2010 PF gate	

PROVISIONS BY OTHERS

GENERAL
HOISTWAY - THE HOISTWAY MUST BE DESIGNED AND BUILT IN ACCORDANCE WITH 'SAFETY STANDARD FOR PLATFORM LIFTS AND STAIRWAY CHAIRLIFTS' OR 'SAFETY CODE FOR ELEVATORS AND ESCALATORS' AND ALL STATE/PROVINCIALS AND LOCAL CODES.
PLUMB RUNWAY- DUE TO CLOSE RUNNING CLEARANCES OWNER/AGENT MUST ENSURE THAT HOISTWAY AND PIT (WHERE PROVIDED) ARE LEVEL, PLUMB (-/+ 1/8" (3 mm)) AND SQUARE AND ARE IN ACCORDANCE WITH THE DIMENSIONS ON THESE DRAWINGS.
MINIMUM OVERHEAD CLEARANCE- OWNER/AGENT MUST ENSURE MINIMUM OVERHEAD CLEARANCE IS IN COMPLIANCE WITH CODES.
CONSTRUCTION SITE- OWNER/AGENT TO PROVIDE ALL MASONRY, CARPENTRY AND DRYWALL WORK AS REQUIRED AND SHALL PATCH AND MAKE GOOD (INCLUDING FINISH PAINTING) ALL AREAS WHERE WALLS/FLOORS MAY REQUIRE TO BE CUT, DRILLED OR ALTERED IN ANY WAY TO PERMIT THE PROPER INSTALLATION OF THE LIFT.
DIMENSIONS- CONTRACTOR/CUSTOMER TO VERIFY ALL DIMENSIONS AND REPORT ANY DISCREPANCIES TO OUR OFFICE IMMEDIATELY.
STRUCTURAL
FLOOR/SUPPORT WALL LOADS-STRUCTURAL ENGINEER TO ASSURE THAT BUILDING AND SHAFT WILL SAFELY SUPPORT ALL LOADS IMPOSED BY THE LIFT EQUIPMENT. REFER TO THE LOAD DIAGRAM ON THIS DRAWING.
MAST TO BE SECURELY FASTENED- WHERE REQUIRED THE MAST MUST BE SECURELY FASTENED TO THE STRUCTURAL SUPPORT WALL. REFER TO WALL / FLOOR SUPPORT LOAD DIAGRAM AND WALL LAG DIMENSIONS ON THIS DRAWING.
WHERE DOORS ARE REQUIRED- SUITABLE LINTELS MUST BE PROVIDED BY OWNER/AGENT. DOOR FRAMES ARE NOT DESIGNED TO SUPPORT OVERHEAD WALL LOADS.

ELECTRICAL
GENERAL- ELECTRICAL EQUIPMENT AND WIRING TO COMPLY WITH SECTION 38 OF CSA C22.1 (CANADA) OR SECTION 620 OF NEC ANSI/NFPA 70 (USA).
POWER SUPPLY- 120VAC, 20A, 60HZ, 1PH CIRCUIT THROUGH A FUSE DISCONNECT WITH AUXILIARY CONTACT ON MAIN POWER SUPPLY. PROVIDE TWO 18 AWG CONDUCTORS BETWEEN CONTACT AND CONTROLLER.
LIGHTING-LIGHTING OF 100 LX MIN. AT PLATFORM AND LANDINGS. LIGHTING WITH SWITCH AND ELECTRICAL GFCI OUTLET IN HOISTWAY PIT.
ADDITIONAL BRANCH CIRCUIT- FOR DOOR OPERATORS (IF EQUIPPED) (120VAC, 15A, 60HZ, 1PH) BRANCH CIRCUIT WITH DISCONNECT FOR VENTILATION SYSTEM (IF EQUIPPED) (120VAC, 15A, 60HZ, 1PH)
ENTRANCES
UPPER LANDING GATES- WHERE REQUIRED, SMOOTH SOLID BARRIERS ARE TO BE SUPPLIED AND INSTALLED ON BOTH SIDES OF ENTRANCE AT UPPER LEVEL AND MUST BE A MINIMUM OF 42" (1067 mm) HIGH. ENTRANCE ASSEMBLY MUST BE IN PLACE PRIOR TO THIS PROVISION.
FASCIA PANEL BELOW UPPER LEVEL ENTRANCE- WHERE REQUIRED, FASCIA PANEL MUST BE FASTENED TO A SOLID WALL AND BE PERPENDICULAR TO THE FLOOR AND WALLS. HOISTWAY FASCIA IS NOT SELF-SUPPORTING FOR LONG, CONTINUOUS RUNS VOID OF ENTRANCES. ADEQUATE SUPPORT FOR THE FASCIA MUST BE PROVIDED.
ENTRANCE ASSEMBLIES- ENTRANCE ASSEMBLIES MUST BE ADJUSTED TO ALIGN WITH PLATFORM AND INTERLOCK EQUIPMENT. OTHERS TO ALLOW AN ADEQUATE ROUGH OPENING.
RETURN WALLS- RETURN WALLS AT ENTRANCES MUST BE BUILT-IN BY OTHERS AFTER ENTRANCE ASSEMBLIES ARE IN PLACE. ENTRANCE ASSEMBLY MUST BE SECURELY FASTENED TO WALLS.